



## Wireline Ram Assembly

**Wireline Ram Assembly** is the core seal parts of a Wireline BOP. It is main consist of Ram Body, Inner Seal and Outer Seal. One size Ram Assembly usually corresponds to one size Wire. And the Ram Assembly may differ in BOP which has different I.D. because the Hydraulic Cylinder of the BOPs may different. In addition, it should keep two sets of Wireline Ram Assemblies with same size at least when Dual Ram BOP or Triple Ram BOP applied in operation.

The main difference of the Wireline Ram Assembly and Slickline Ram Assembly is that the Inner Seal applied. Which a Blind Rubber Seal is fitted on the Inner Seal of the Slickline Ram Assembly.

Normally, our Wireline Ram Assembly only meet with our Wireline BOP. The Ram dimension maybe differ in different companies products. And the accessories such as Inner Seal and Outer Seal may not interchange with other companies too.

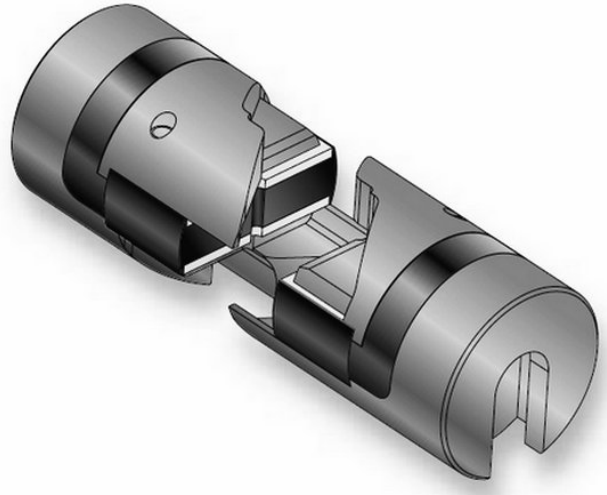

### Feature

- 1) Quality steel alloy or stainless steel Ram Body.
- 2) Proper materials applied to the Ram Body and Rubber Seal according to service environment and temperature.
- 3) Easy to replace.
- 4) Shear Seal Ram Assembly and Multi line Ram Assembly apply allowed.

### Normal Guarantee Period

12 months after the clients received the Equipment  
or 13 months after the commodity be shipped from Chinese Harbor ( Except the Rubber Seal ).

### Information Required When Inquiry

If you will purchase the whole Wireline PCE,  
please refer to the [Information Required When Inquiry](#) in Chapter 《Wireline PCE》 .

Subject to change without notice