

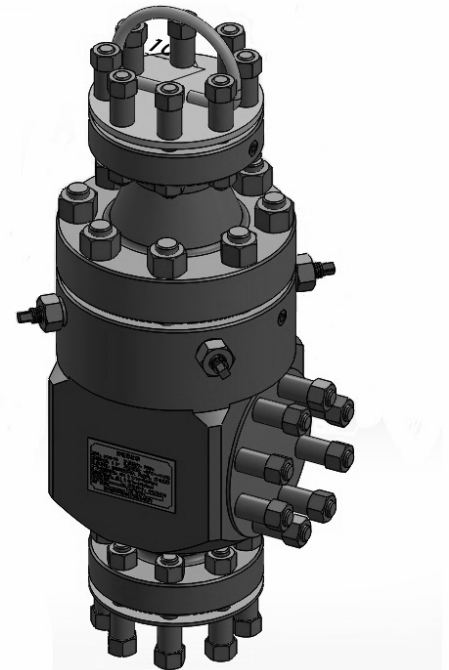

Coiled tubing Hanger

The **Coiled Tubing Hanger** is a long term coiled tubing Hanger consists of a Hanger Cartridge, Slip, Packing Rubber, and Upper Connector. It main apply for gas production in a velocity string. This Coiled Tubing Hanger adopts unique design structure, has the feature of simple operation, safety and reliable suspension.

The upper and lower ends of the Coiled Tubing Hanger are flange connected. During operation, the upper end is connected to the Operation Window, and the lower end is connected to the wellhead Christmas Tree no. 1 valve. When the coiled tubing is placed in position, tighten the jackscrew to seal the coiled tubing manually, then running the Slip into the Coiled Tubing Hanger from the Operation Window, downward press the coiled tubing from the CT Injection Head to lock the slips and hang the coiled tubing. After the coiled tubing be sealed and hanged firmly, cutting the coiled tubing, install the gas tree on the upper of the Coiled Tubing Hanger, and remove the plug in the front of the coiled tubing to resume gas production.



Feature

- 1) Be used with the Operation Window, simple structure, convenient operation and reliable hanging.
- 2) Cone slips allow automatic clamp coiled tubing.
- 3) Upper and lower seals provide reliable sealing.
- 4) Available in a complete range of sizes and pressure ratings.

Main Parameter

- 1) I.D.
- 2) Working Pressure
- 3) Coiled tubing size you applied
- 4) Upper and Lower connection required
- 5) Service Environment (STD or H2S)
- 6) Working Temperature



Coiled Tubing Hanger

Model	Working Pressure	Normal I.D.	CT Size	Hang Force	Side Connection	Upper & Lower Connection	Service	Working Temperature
CXG6-35	5000Psi	2-9/16"	1.25" / 1.5"	12.8t / 15t	API 2 9/16"-5K (R27) Flange	API 2 9/16"-5K (R27) Flange	STD or H2S	P + U -20°F~+250°F (-29°C~+121°C) Or As Required
CXG6-70	10000Psi				API 2 9/16"-10K (BX153) Flange	API 2 9/16"-10K (BX153) Flange		
CXG7-35	5000Psi	3-1/16"	1.5" / 1.75"	15t / 18.5t	API 2 9/16"-5K (R27) Flange	API 3 18"-5K (R35) Flange		
CXG7-70	10000Psi				API 2 9/16"-10K (BX153) Flange	API 3 1/16"-10K (BX154) Flange		
CXG10-35	5000Psi	4-1/16"	1.5" / 1.75" / 2.0"	15t / 18.5t / 20t	API 2 9/16"-5K (R27) Flange	API 4 1/16"-5K (R39) Flange		
CXG10-70	10000Psi				API 2 9/16"-10K (BX153) Flange	API 4 1/16"-10K (BX155) Flange		

Note

1) Additional size available on request.

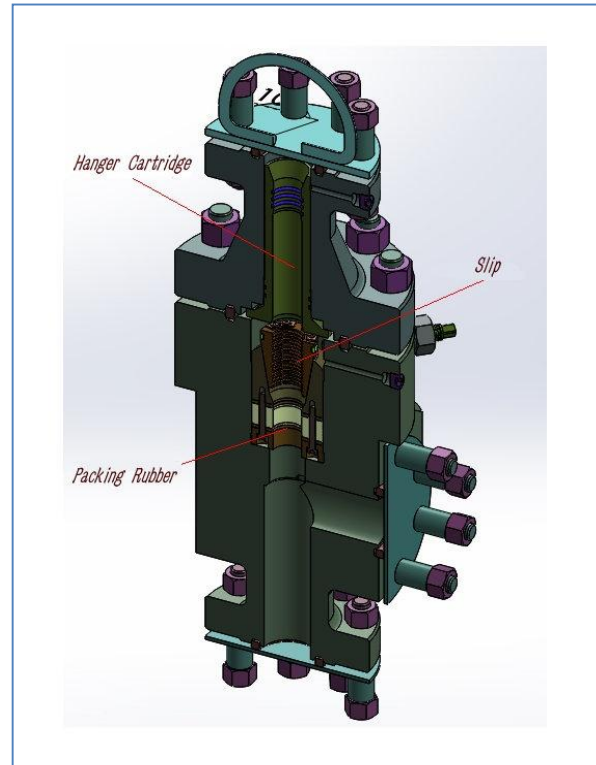

Normal Guarantee Period

12 months after the clients received the Equipment
or 13 months after the commodity be shipped from Chinese Harbor.



Information Required When Inquiry

Main Parameter information above mentioned will be asked.

Subject to change without notice